

## Clamping Bolts

**Steel, Downward Clamping, with Threaded Bolt, Screw from the Operator's side, Screw from the Back**

### SPECIFICATION

#### Types

- Type **KV / KVS / KVB**: With ball lever, angular (serration)
- Type **GV / GVS / GVB**: With ball lever, straight (serration)
- Type **SK / SKS / SKB**: With hex

#### Clamping direction

- Type **R**: By clockwise rotation (drawn version)
- Type **L**: By anti-clockwise rotation

Steel

#### Version with Threaded Bolt

- Clamping bolt and thrust washer  
Case-hardened
- Threaded bolt nitrided  
Property class 8.8
- Lever  
Blackened

#### Version with Screw from the Operator's Side

- Clamping bolt, guide bushing and thrust washer  
Case-hardened
- Socket cap screw DIN 912-12.9
- Lever  
Blackened

#### Version with Screw from the Back

- Clamping bolt, threaded bushing and thrust washer  
Case-hardened
- Socket cap screw DIN 912-12.9
- Washer tempered
- Lever blackened

Ball knob DIN 319 (see page )

Plastic, Duroplast

Black, shiny finish



### INFORMATION

Clamping bolts GN 918.2 have a circumferential wedge surface. They allow for rapid and secure clamping and releasing with a relatively large clamping range and with high clamping force. Owing to the small pitch angle (wedge angle), the clamping bolt is self-locking. The ball levers of types KV / KVS / KVB and GV / GVS / GVB form a positive connection with the clamping bolt by means of a serration. During assembly, the lever can thus be fixed in a position favorable for clamping or, in the relaxed position, rotated out of the clamping range.

#### Version with Threaded Bolt

Use of the thrust washer eliminates the need for special requirements on the design of the threaded hole, which allows, for example, fastening to tables with T-slots.

#### Version with Screw from the Operator's Side

Fastening via screw from the operator's side bridges a greater clamping range. A sufficiently large screw-in depth  $t$  is necessary to safely absorb the screw forces.

#### Version with Screw from the Back

Fastening with a bushing allows the part to be used even if there is no thread in the surrounding structure. The heavy duty washer directs the resulting screw forces into the surrounding structure.

### TECHNICAL INFORMATION

- Technical instructions (see page )
- Strength Values of Screws (see page A20)
- Plastic Characteristics (see page A2)

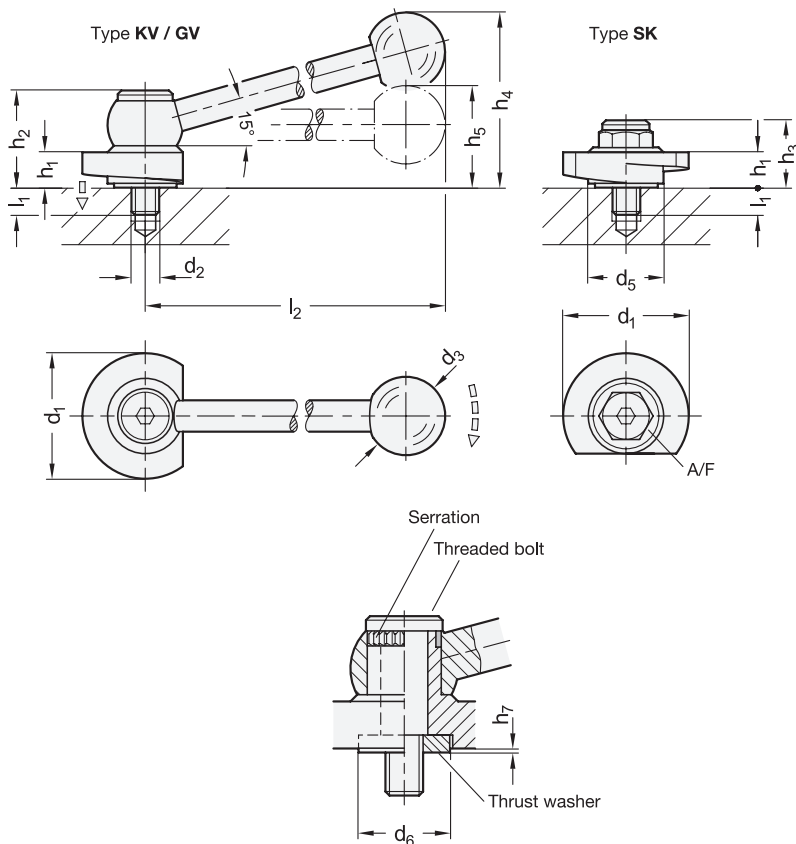

\* Complete with

**R** By clockwise rotation (drawn version)      **L** By anti-clockwise rotation

**GN 918.2-KV**

Description	d1 -0.5	d2	d3	d5	d6	h1	h2	h4 ≈	h5	h7 ≈	l1	l2 ≈	ΔΔ
GN 918.2-40-KV-*	40	M 8	25	24	20	10	31	55	31	0.2	8	100	232
GN 918.2-50-KV-*	50	M 10	30	28	24	12	35	62	36	0.2	11	116	292

**GN 918.2-GV**

Description	d1 -0.5	d2	d3	d5	d6	h1	h2	h4 ≈	h5	h7 ≈	l1	l2 ≈	ΔΔ
GN 918.2-40-GV-*	40	M 8	25	24	20	10	31	55	31	0.2	8	100	292
GN 918.2-50-GV-*	50	M 10	30	28	24	12	35	62	36	0.2	11	116	306

**GN 918.2-SK**

Description	d1 -0.5	d2	d5	d6	h1	h3	h7 ≈	l1	A/F	ΔΔ
GN 918.2-40-SK-*	40	M 8	24	20	10	21.5	0.2	8	15	86
GN 918.2-50-SK-*	50	M 10	28	24	12	24.5	0.2	11	19	150

Weight type R



9

Machine elements

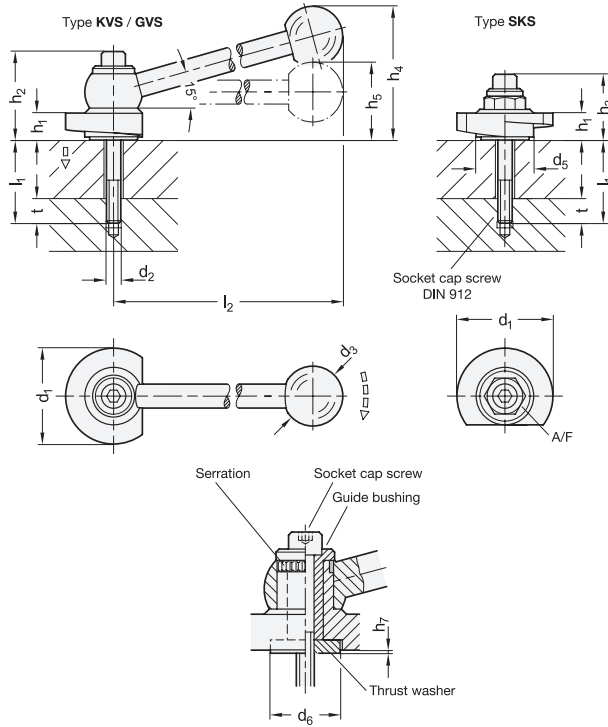

\* Complete with

**R** By clockwise rotation (drawn version)

**L** By anti-clockwise rotation

GN 918.2-KVS

Description	d1 -0.5	l1	d2	d3	d5	d6	h1	h2	h4 ≈	h5	h7 ≈	l2 ≈	△
GN 918.2-40-KVS-*-10	40	10	M 6	25	24	20	10	36	55	31	0.2	100	234
GN 918.2-40-KVS-*-15	40	15	M 6	25	24	20	10	36	55	31	0.2	100	235
GN 918.2-40-KVS-*-20	40	20	M 6	25	24	20	10	36	55	31	0.2	100	236
GN 918.2-40-KVS-*-25	40	25	M 6	25	24	20	10	36	55	31	0.2	100	237
GN 918.2-40-KVS-*-30	40	30	M 6	25	24	20	10	36	55	31	0.2	100	238
GN 918.2-40-KVS-*-40	40	40	M 6	25	24	20	10	36	55	31	0.2	100	240
GN 918.2-40-KVS-*-45	40	45	M 6	25	24	20	10	36	55	31	0.2	100	240
GN 918.2-40-KVS-*-50	40	50	M 6	25	24	20	10	36	55	31	0.2	100	241
GN 918.2-40-KVS-*-60	40	60	M 6	25	24	20	10	36	55	31	0.2	100	243
GN 918.2-40-KVS-*-65	40	65	M 6	25	24	20	10	36	55	31	0.2	100	245
GN 918.2-40-KVS-*-70	40	70	M 6	25	24	20	10	36	55	31	0.2	100	247
GN 918.2-40-KVS-*-80	40	80	M 6	25	24	20	10	36	55	31	0.2	100	248
GN 918.2-40-KVS-*-90	40	90	M 6	25	24	20	10	36	55	31	0.2	100	251
GN 918.2-50-KVS-*-12	50	12	M 8	30	28	24	12	41	62	36	0.2	116	292
GN 918.2-50-KVS-*-22	50	22	M 8	30	28	24	12	41	62	36	0.2	116	296
GN 918.2-50-KVS-*-32	50	32	M 8	30	28	24	12	41	62	36	0.2	116	300
GN 918.2-50-KVS-*-42	50	42	M 8	30	28	24	12	41	62	36	0.2	116	303
GN 918.2-50-KVS-*-52	50	52	M 8	30	28	24	12	41	62	36	0.2	116	308
GN 918.2-50-KVS-*-62	50	62	M 8	30	28	24	12	41	62	36	0.2	116	311
GN 918.2-50-KVS-*-72	50	72	M 8	30	28	24	12	41	62	36	0.2	116	315
GN 918.2-50-KVS-*-82	50	82	M 8	30	28	24	12	41	62	36	0.2	116	319
GN 918.2-50-KVS-*-92	50	92	M 8	30	28	24	12	41	62	36	0.2	116	321
GN 918.2-50-KVS-*-102	50	102	M 8	30	28	24	12	41	62	36	0.2	116	319
GN 918.2-50-KVS-*-112	50	112	M 8	30	28	24	12	41	62	36	0.2	116	328

Weight type R



Machine elements 9

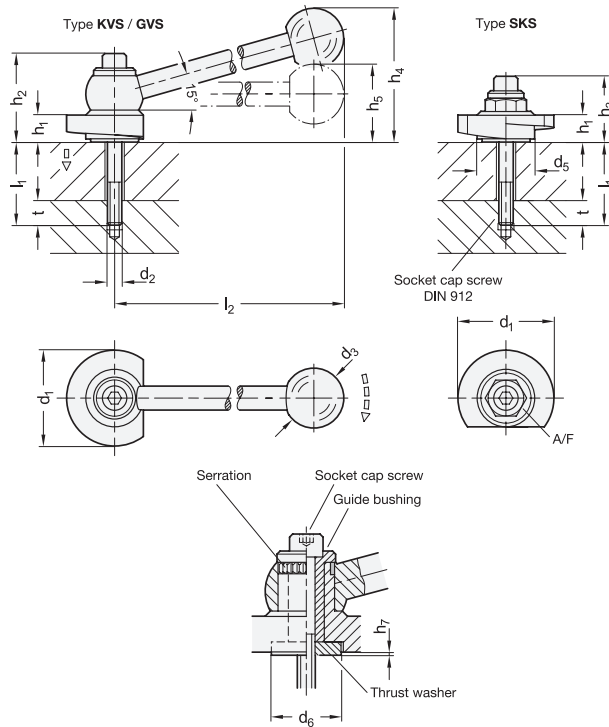

\* Complete with

R By clockwise rotation (drawn version)

L By anti-clockwise rotation

GN 918.2-GVS

Description	d1 -0.5	l1	d2	d3	d5	d6	h1	h2	h4 ≈	h5	h7 ≈	l2 ≈	⚖
GN 918.2-40-GVS-*-10	40	10	M 6	25	24	20	10	36	55	31	0.2	100	234
GN 918.2-40-GVS-*-15	40	15	M 6	25	24	20	10	36	55	31	0.2	100	235
GN 918.2-40-GVS-*-20	40	20	M 6	25	24	20	10	36	55	31	0.2	100	236
GN 918.2-40-GVS-*-25	40	25	M 6	25	24	20	10	36	55	31	0.2	100	237
GN 918.2-40-GVS-*-30	40	30	M 6	25	24	20	10	36	55	31	0.2	100	238
GN 918.2-40-GVS-*-40	40	40	M 6	25	24	20	10	36	55	31	0.2	100	240
GN 918.2-40-GVS-*-45	40	45	M 6	25	24	20	10	36	55	31	0.2	100	240
GN 918.2-40-GVS-*-50	40	50	M 6	25	24	20	10	36	55	31	0.2	100	241
GN 918.2-40-GVS-*-60	40	60	M 6	25	24	20	10	36	55	31	0.2	100	243
GN 918.2-40-GVS-*-65	40	65	M 6	25	24	20	10	36	55	31	0.2	100	245
GN 918.2-40-GVS-*-70	40	70	M 6	25	24	20	10	36	55	31	0.2	100	247
GN 918.2-40-GVS-*-80	40	80	M 6	25	24	20	10	36	55	31	0.2	100	248
GN 918.2-40-GVS-*-90	40	90	M 6	25	24	20	10	36	55	31	0.2	100	251
GN 918.2-50-GVS-*-12	50	12	M 8	30	28	24	12	41	62	36	0.2	116	292
GN 918.2-50-GVS-*-22	50	22	M 8	30	28	24	12	41	62	36	0.2	116	296
GN 918.2-50-GVS-*-32	50	32	M 8	30	28	24	12	41	62	36	0.2	116	300
GN 918.2-50-GVS-*-42	50	42	M 8	30	28	24	12	41	62	36	0.2	116	303
GN 918.2-50-GVS-*-52	50	52	M 8	30	28	24	12	41	62	36	0.2	116	308
GN 918.2-50-GVS-*-62	50	62	M 8	30	28	24	12	41	62	36	0.2	116	311
GN 918.2-50-GVS-*-72	50	72	M 8	30	28	24	12	41	62	36	0.2	116	315
GN 918.2-50-GVS-*-82	50	82	M 8	30	28	24	12	41	62	36	0.2	116	319
GN 918.2-50-GVS-*-92	50	92	M 8	30	28	24	12	41	62	36	0.2	116	321
GN 918.2-50-GVS-*-102	50	102	M 8	30	28	24	12	41	62	36	0.2	116	319
GN 918.2-50-GVS-*-112	50	112	M 8	30	28	24	12	41	62	36	0.2	116	328

Weight type R



Machine elements

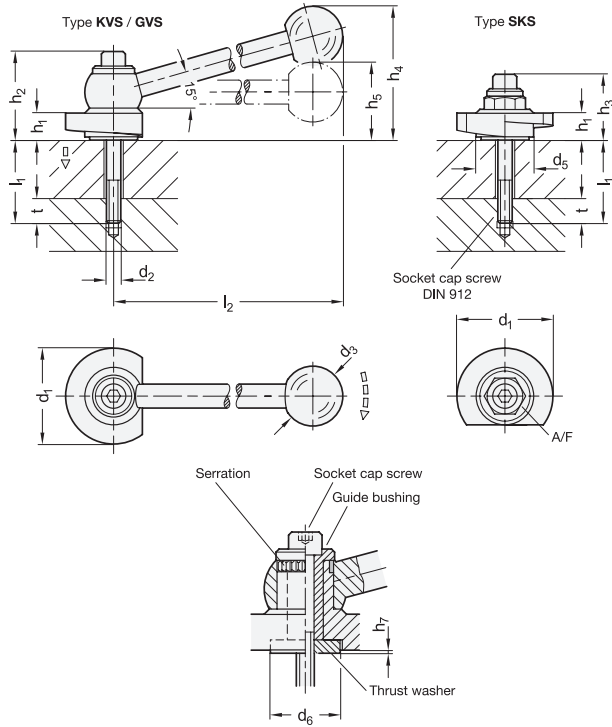

\* Complete with

**R** By clockwise rotation (drawn version)

**L** By anti-clockwise rotation

**GN 918.2-SKS**

Description	d1 -0.5	l1	d2	d5	d6	h1	h3	h7 ≈	A/F	⚖
GN 918.2-40-SKS-*-15	40	15	M6	24	20	10	26	0.2	15	683
GN 918.2-40-SKS-*-20	40	20	M6	24	20	10	26	0.2	15	683
GN 918.2-40-SKS-*-25	40	25	M6	24	20	10	26	0.2	15	685
GN 918.2-40-SKS-*-30	40	30	M6	24	20	10	26	0.2	15	685
GN 918.2-40-SKS-*-35	40	35	M6	24	20	10	26	0.2	15	687
GN 918.2-40-SKS-*-40	40	40	M6	24	20	10	26	0.2	15	688
GN 918.2-40-SKS-*-50	40	50	M6	24	20	10	26	0.2	15	689
GN 918.2-40-SKS-*-55	40	55	M6	24	20	10	26	0.2	15	689
GN 918.2-40-SKS-*-60	40	60	M6	24	20	10	26	0.2	15	691
GN 918.2-40-SKS-*-70	40	70	M6	24	20	10	26	0.2	15	693
GN 918.2-40-SKS-*-75	40	75	M6	24	20	10	26	0.2	15	695
GN 918.2-40-SKS-*-80	40	80	M6	24	20	10	26	0.2	15	697
GN 918.2-40-SKS-*-90	40	90	M6	24	20	10	26	0.2	15	699
GN 918.2-50-SKS-*-12	50	12	M8	28	24	12	31	0.2	19	160
GN 918.2-50-SKS-*-22	50	22	M8	28	24	12	31	0.2	19	164
GN 918.2-50-SKS-*-32	50	32	M8	28	24	12	31	0.2	19	168
GN 918.2-50-SKS-*-42	50	42	M8	28	24	12	31	0.2	19	171
GN 918.2-50-SKS-*-52	50	52	M8	28	24	12	31	0.2	19	176
GN 918.2-50-SKS-*-62	50	62	M8	28	24	12	31	0.2	19	179
GN 918.2-50-SKS-*-72	50	72	M8	28	24	12	31	0.2	19	183
GN 918.2-50-SKS-*-82	50	82	M8	28	24	12	31	0.2	19	187
GN 918.2-50-SKS-*-92	50	92	M8	28	24	12	31	0.2	19	189
GN 918.2-50-SKS-*-102	50	102	M8	28	24	12	31	0.2	19	187
GN 918.2-50-SKS-*-112	50	112	M8	28	24	12	31	0.2	19	196

Weight type R



Machine elements 9

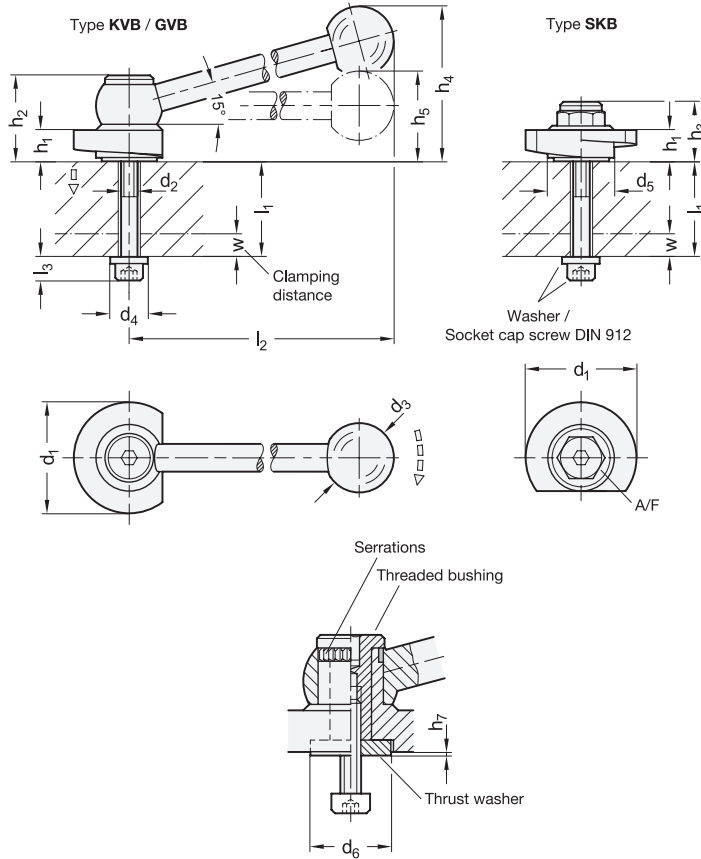

\* Complete with

**R**  
By clockwise rotation (drawn version)

**L**  
By anti-clockwise rotation

**GN 918.2-KVB**

Description	d1 -0.5	l1 max.	d2	d3	d4	d5	d6	h1	h2	h4 ≈	h5	h7 ≈	l2 ≈	w max.	⚖
GN 918.2-40-KVB-*-12	40	12	M6	25	12	24	20	10	30.5	55	31	0.2	100	5	235
GN 918.2-40-KVB-*-22	40	22	M6	25	12	24	20	10	30.5	55	31	0.2	100	5	237
GN 918.2-40-KVB-*-27	40	27	M6	25	12	24	20	10	30.5	55	31	0.2	100	5	238
GN 918.2-40-KVB-*-32	40	32	M6	25	12	24	20	10	30.5	55	31	0.2	100	5	239
GN 918.2-40-KVB-*-37	40	37	M6	25	12	24	20	10	30.5	55	31	0.2	100	5	240
GN 918.2-40-KVB-*-42	40	42	M6	25	12	24	20	10	30.5	55	31	0.2	100	5	241
GN 918.2-40-KVB-*-47	40	47	M6	25	12	24	20	10	30.5	55	31	0.2	100	5	242
GN 918.2-40-KVB-*-57	40	57	M6	25	12	24	20	10	30.5	55	31	0.2	100	5	244
GN 918.2-40-KVB-*-62	40	62	M6	25	12	24	20	10	30.5	55	31	0.2	100	5	244
GN 918.2-40-KVB-*-67	40	67	M6	25	12	24	20	10	30.5	55	31	0.2	100	5	245
GN 918.2-40-KVB-*-77	40	77	M6	25	12	24	20	10	30.5	55	31	0.2	100	5	247
GN 918.2-40-KVB-*-82	40	82	M6	25	12	24	20	10	30.5	55	31	0.2	100	5	249
GN 918.2-50-KVB-*-10	50	10	M8	30	16	28	24	12	34.5	62	36	0.2	116	5	296
GN 918.2-50-KVB-*-20	50	20	M8	30	16	28	24	12	34.5	62	36	0.2	116	5	298
GN 918.2-50-KVB-*-30	50	30	M8	30	16	28	24	12	34.5	62	36	0.2	116	5	302
GN 918.2-50-KVB-*-40	50	40	M8	30	16	28	24	12	34.5	62	36	0.2	116	5	306
GN 918.2-50-KVB-*-50	50	50	M8	30	16	28	24	12	34.5	62	36	0.2	116	5	310
GN 918.2-50-KVB-*-60	50	60	M8	30	16	28	24	12	34.5	62	36	0.2	116	5	313
GN 918.2-50-KVB-*-70	50	70	M8	30	16	28	24	12	34.5	62	36	0.2	116	5	318
GN 918.2-50-KVB-*-80	50	80	M8	30	16	28	24	12	34.5	62	36	0.2	116	5	321
GN 918.2-50-KVB-*-90	50	90	M8	30	16	28	24	12	34.5	62	36	0.2	116	5	325
GN 918.2-50-KVB-*-100	50	100	M8	30	16	28	24	12	34.5	62	36	0.2	116	5	329

Weight type R



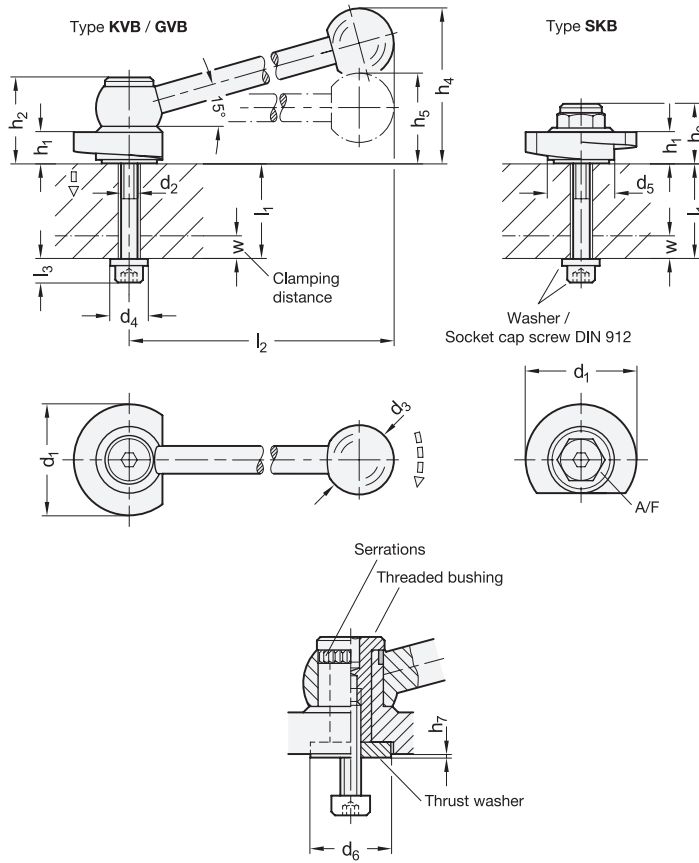

\* Complete with

R By clockwise rotation (drawn version) L By anti-clockwise rotation

GN 918.2-GVB

Description	d1 -0.5	h1 max.	d2	d3	d4	d5	d6	h1	h2	h4 ≈	h5	h7 ≈	l2 ≈	w max.	⚖
GN 918.2-40-GVB-*-12	40	12	M 6	25	12	24	20	10	30.5	55	31	0.2	100	5	235
GN 918.2-40-GVB-*-22	40	22	M 6	25	12	24	20	10	30.5	55	31	0.2	100	5	237
GN 918.2-40-GVB-*-27	40	27	M 6	25	12	24	20	10	30.5	55	31	0.2	100	5	238
GN 918.2-40-GVB-*-32	40	32	M 6	25	12	24	20	10	30.5	55	31	0.2	100	5	239
GN 918.2-40-GVB-*-37	40	37	M 6	25	12	24	20	10	30.5	55	31	0.2	100	5	240
GN 918.2-40-GVB-*-42	40	42	M 6	25	12	24	20	10	30.5	55	31	0.2	100	5	241
GN 918.2-40-GVB-*-47	40	47	M 6	25	12	24	20	10	30.5	55	31	0.2	100	5	242
GN 918.2-40-GVB-*-57	40	57	M 6	25	12	24	20	10	30.5	55	31	0.2	100	5	244
GN 918.2-40-GVB-*-62	40	62	M 6	25	12	24	20	10	30.5	55	31	0.2	100	5	244
GN 918.2-40-GVB-*-67	40	67	M 6	25	12	24	20	10	30.5	55	31	0.2	100	5	245
GN 918.2-40-GVB-*-77	40	77	M 6	25	12	24	20	10	30.5	55	31	0.2	100	5	247
GN 918.2-40-GVB-*-82	40	82	M 6	25	12	24	20	10	30.5	55	31	0.2	100	5	249
GN 918.2-50-GVB-*-10	50	10	M 8	30	16	28	24	12	34.5	62	36	0.2	116	5	296
GN 918.2-50-GVB-*-20	50	20	M 8	30	16	28	24	12	34.5	62	36	0.2	116	5	298
GN 918.2-50-GVB-*-30	50	30	M 8	30	16	28	24	12	34.5	62	36	0.2	116	5	302
GN 918.2-50-GVB-*-40	50	40	M 8	30	16	28	24	12	34.5	62	36	0.2	116	5	306
GN 918.2-50-GVB-*-50	50	50	M 8	30	16	28	24	12	34.5	62	36	0.2	116	5	310
GN 918.2-50-GVB-*-60	50	60	M 8	30	16	28	24	12	34.5	62	36	0.2	116	5	313
GN 918.2-50-GVB-*-70	50	70	M 8	30	16	28	24	12	34.5	62	36	0.2	116	5	318
GN 918.2-50-GVB-*-80	50	80	M 8	30	16	28	24	12	34.5	62	36	0.2	116	5	321
GN 918.2-50-GVB-*-90	50	90	M 8	30	16	28	24	12	34.5	62	36	0.2	116	5	325
GN 918.2-50-GVB-*-100	50	100	M 8	30	16	28	24	12	34.5	62	36	0.2	116	5	329

Weight type R



Machine elements 9

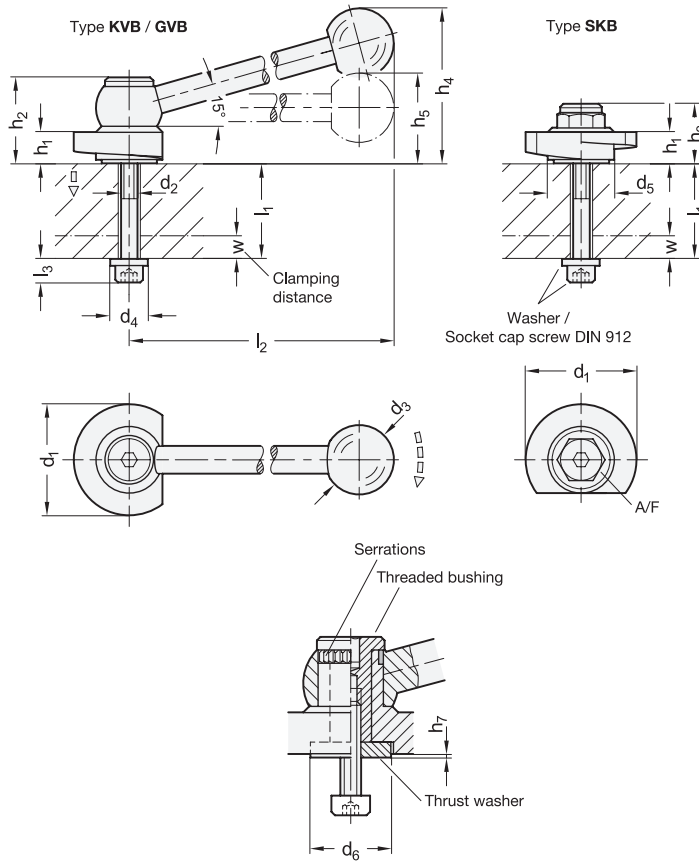

\* Complete with

**R** By clockwise rotation (drawn version)      **L** By anti-clockwise rotation

**GN 918.2-SKB**

Description	d1 -0.5	l1 max.	d2	d4	d5	d6	h1	h3	h5	h7 ≈	A/F	w max.	⚖
GN 918.2-40-SKB-*-12	40	12	M 6	12	24	20	10	21	31	0.2	15	5	683
GN 918.2-40-SKB-*-22	40	22	M 6	12	24	20	10	21	31	0.2	15	5	685
GN 918.2-40-SKB-*-27	40	27	M 6	12	24	20	10	21	31	0.2	15	5	687
GN 918.2-40-SKB-*-32	40	32	M 6	12	24	20	10	21	31	0.2	15	5	687
GN 918.2-40-SKB-*-37	40	37	M 6	12	24	20	10	21	31	0.2	15	5	689
GN 918.2-40-SKB-*-42	40	42	M 6	12	24	20	10	21	31	0.2	15	5	689
GN 918.2-40-SKB-*-47	40	47	M 6	12	24	20	10	21	31	0.2	15	5	691
GN 918.2-40-SKB-*-57	40	57	M 6	12	24	20	10	21	31	0.2	15	5	692
GN 918.2-40-SKB-*-62	40	62	M 6	12	24	20	10	21	31	0.2	15	5	693
GN 918.2-40-SKB-*-67	40	67	M 6	12	24	20	10	21	31	0.2	15	5	693
GN 918.2-40-SKB-*-77	40	77	M 6	12	24	20	10	21	31	0.2	15	5	695
GN 918.2-40-SKB-*-82	40	82	M 6	12	24	20	10	21	31	0.2	15	5	697
GN 918.2-50-SKB-*-10	50	10	M 8	16	28	24	12	24	36	0.2	19	5	160
GN 918.2-50-SKB-*-20	50	20	M 8	16	28	24	12	24	36	0.2	19	5	162
GN 918.2-50-SKB-*-30	50	30	M 8	16	28	24	12	24	36	0.2	19	5	166
GN 918.2-50-SKB-*-40	50	40	M 8	16	28	24	12	24	36	0.2	19	5	170
GN 918.2-50-SKB-*-50	50	50	M 8	16	28	24	12	24	36	0.2	19	5	174
GN 918.2-50-SKB-*-60	50	60	M 8	16	28	24	12	24	36	0.2	19	5	177
GN 918.2-50-SKB-*-70	50	70	M 8	16	28	24	12	24	36	0.2	19	5	182
GN 918.2-50-SKB-*-80	50	80	M 8	16	28	24	12	24	36	0.2	19	5	185
GN 918.2-50-SKB-*-90	50	90	M 8	16	28	24	12	24	36	0.2	19	5	189
GN 918.2-50-SKB-*-100	50	100	M 8	16	28	24	12	24	36	0.2	19	5	193

Weight type R



Machine elements